

RECOMMEND P.C.B LAYOUT(COMPONENT SIDE)  
TOLERANCE FOR PCB LAYOUT IS ± 0.05

USB TYPE-C PIN ASSIGNMENTS

PIN NUMBER	SIGNAL NAME	PIN NUMBER	SIGNAL NAME
A1	GND	B12	GND
A4	VBUS	B9	VBUS
A5	CC1	B8	SBU2
A6	Dp1	B7	Dn2
A7	Dn1	B6	Dp2
A8	SBU1	B5	CC2
A9	VBUS	B4	VBUS
A12	GND	B1	GND

REV	DESCRIPTION	DATE	APPROVED
A	新板发行	2023.05.05	HHM

NOTE:

- 备注:
- MATERIAL SPECIFICATION:
    - 材料规格:
      - HOUSING: HIGH TEMPERATURE RESISTANT PLASTIC, UL94 V-0
      - 胶芯材料: 高温塑胶, 防火等级 UL94 V-0
      - TERMINAL: COPPER ALLOY
      - 端子材料: 铜合金
      - FRONT SHELL: STAINLESS STEEL
      - 外壳材料: 不锈钢
      - MID PLATE: STAINLESS STEEL
      - 中夹片: 不锈钢
    - PLATING SPECIFICATION:
      - 电镀规格:
        - TERMINAL:
          - 端子: Ni 30u" MIN. UNDER PLATED OVER ALL. 镀镍底 30u" MIN.
          - 表面刷金 Golden Flash
        - FRONT SHELL:
          - 外壳: Ni 30u" MIN. PLATED OVER ALL. 镀镍底 30u" MIN.
      - MECHANICAL PERFORMANCE,
        - 机械性能:
          - INSERTION FORCE: 0.5~2.0kgf.
            - 插入力: 0.5~2.0kgf.
            - REMOVAL FORCE: 0.6kgf~2.0kgf.
              - 拔出力: 0.6kgf~2.0kgf.
            - DURABILITY: 10000 CYCLES.
              - 插拔寿命: 10000次.
          - ELECTRICAL PERFORMANCE,
            - 电气性能:
              - VOLTAGE RATING: 48V DC/AC
                - 额定电压: 48V DC/AC
                - CURRENT RATING: 5A
                  - 额定电流: 5.0A
                  - LLCR: 50mΩ/PIN MAX.
                    - 接触阻抗: 50mΩ/PIN MAX.
                    - INSULATION RESISTANCE: 100MΩ MIN
                      - 绝缘阻抗: 100MΩ MIN
                      - DIELECTRIC WITHSTAND VOLTAGE, AC 100V FOR 1 MINUTE.
                        - 耐压: AC 100V FOR 1 MINUTE.
                  - ENVIRONMENTAL PERFORMANCE:
                    - 环境特性:
                      - OPERATING TEMPERATURE: -25°C~+85°C.
                        - 工作温度: -25°C~+85°C.

| CUSTOMER DRAWING  |              |                      | 铭创科技(东莞)有限公司  |                     |                |
|---|--------------|----------------------|---|---------------------|----------------|
| UNITS<br>mm   | SCALE<br>1:1 | SHEET<br>1 OF 2      | Mingchuang Technology (Dongguan) Co., Ltd                     |                     |                |
| PROJECTION:<br>   | DRAW:<br>DAP | CHECK:<br>HWT        | TITLE<br>TYPE C母座16PIN 板上后两脚插板SMT L=5.0<br>短体露舌 三模 带中夹片 有柱 有弹 |                     |                |
| GENERAL TOLERANCE<br>.000 ±0.02<br>.00 ±0.10<br>.0 ±0.20<br>.0 ±2°<br>.00 ±1° | APPD:<br>HHM | DWG. NO.<br>A011607A | MAT'L<br>SEE TABLE  | FINISH<br>SEE TABLE | PART NO. _____ |
|   |              |                      |   |                     | SIZE<br>A4     |



|     |             |            |          |
|-----|-------------|------------|----------|
| REV | DESCRIPTION | DATE       | APPROVED |
| A   | 新板发行        | 2023.05.05 | HHM      |

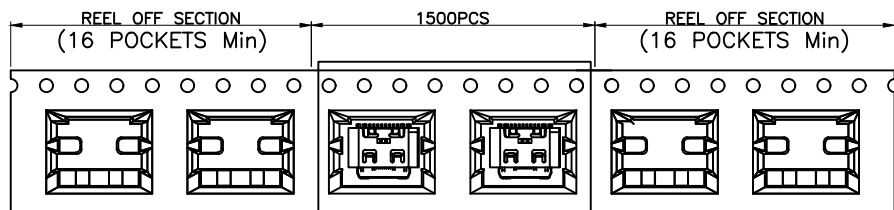

SEE DETAIL X

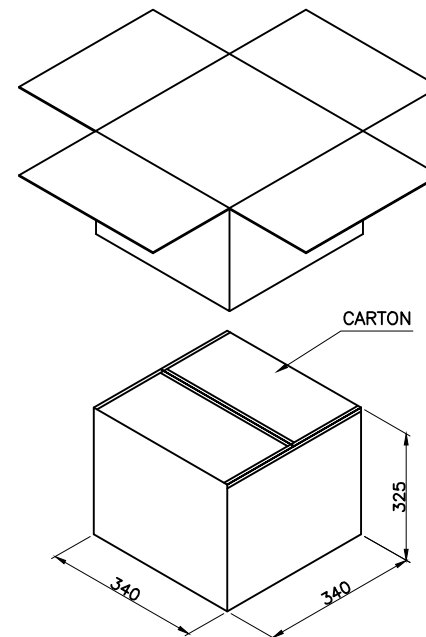
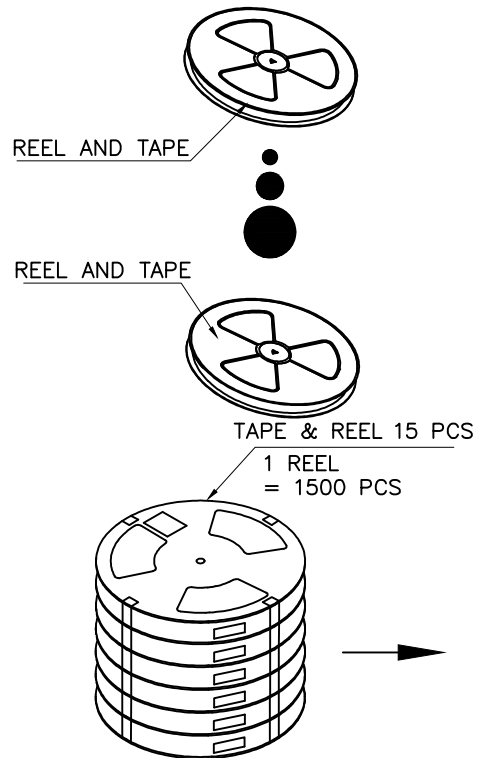
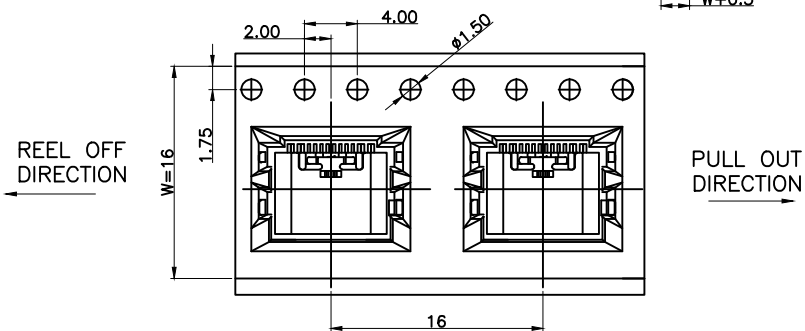
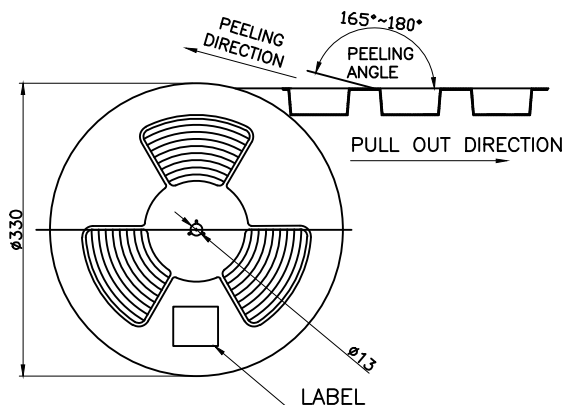

|                 |      |        |
|-----------------|------|--------|
|                 | REEL | CARTON |
| CONNECTOR (PCS) | 1500 | 15000  |

|   |              |                 |   |  |  |
|---|--------------|-----------------|---|--|--|
| CUSTOMER DRAWING  |              |                 | 铭创科技（东莞）有限公司<br>Mingchuang Technology (Dongguan) Co., Ltd     |  |  |
| UNITS<br>mm   | SCALE<br>1:1 | SHEET<br>1 OF 2 | TITLE<br>TYPE C母座16PIN 板上后两脚插板SMT L=5.0<br>短体露舌 三模 带中夹片 有柱 有弹 |  |  |
| PROJECTION:<br>   |              | DRAW:<br>DAP    | MAT'L<br>SEE TABLE      FINISH<br>SEE TABLE                   |  |  |
| GENERAL TOLERANCE<br>.000 ±0.02<br>.00 ±0.10<br>.0 ±0.20<br>.0 ±2°<br>.00 ±1° |              | CHECK:<br>HWT   | DWG. NO.<br>A011607A      PART NO. _____      SIZE<br>A4      |  |  |
|   |              | APPD:<br>HHM    |   |  |  |