

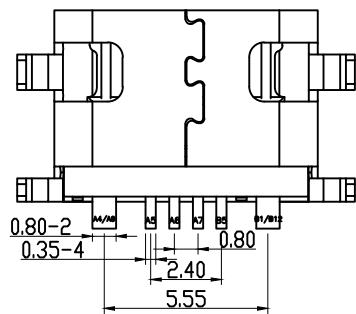

REV	DESCRIPTION	DATE	APPROVED
A	新板发行	2023.05.05	HHM

NOTE:
 备注:
 1. MATERIAL SPECIFICATION:
 1. 材料规格:
 1-1. HOUSING: HIGH TEMPERATURE RESISTANT PLASTIC, UL94 V-0.
 1-1. 胶芯材料: 高温塑胶, 防火等级UL94 V-0
 1-2. TERMINAL: COPPER ALLOY
 1-2. 端子材料: 铜合金
 1-3. FRONT SHELL: STAINLESS STEEL
 1-3. 外壳材料: 不锈钢
 1-4. MID PLATE: STAINLESS STEEL
 1-4. 中夹片: 不锈钢
 2. PLATING SPECIFICATION:
 2. 电镀规格:
 2-1. TERMINAL:
 2-1. 端子:
 Ni 50u" MIN. UNDER PLATED OVER ALL.
 镀镍底 50u" MIN.
 Au PLATED 0.5~1u" OVER Ni
 表面刷金0.5~1u"
 2-2. FRONT SHELL:
 2-2. 外壳:
 Ni 50u" MIN. PLATED OVER ALL.
 镀镍底 50u" MIN.
 3. MECHANICAL PERFORMANCE,
 3. 机械性能,
 3-1. INSERTION FORCE: 0.5~2.0kgf.
 3-1. 插入力: 0.5~2.0kgf.
 3-2. REMOVAL FORCE: 0.6kgf~2.0kgf.
 3-2. 拔出力: 0.6kgf~2.0kgf.
 3-3. DURABILITY: 10000 CYCLES.
 3-3. 插拔寿命: 10000次.
 4. ELECTRICAL PERFORMANCE,
 4. 电气性能,
 4-1. VOLTAGE RATING: 5.0V DC/AC
 4-1. 额定电压: 5.0V DC/AC
 CURRENT RATING: 2.0A
 额定电流: 2.0A
 4-2. LLCR: 50mΩ/PIN MAX.
 4-2. 接触阻抗: 50mΩ/PIN MAX.
 4-3. INSULATION RESISTANCE: 100MΩ MIN
 4-3. 绝缘阻抗: 100MΩ MIN
 4-4. DIELECTRIC WITHSTAND VOLTAGE, AC 100V FOR 1 MINUTE.
 4-4. 耐电压: AC 100V FOR 1 MINUTE.
 5. ENVIRONMENTAL PERFORMANCE:
 5. 环境特性:
 OPERATING TEMPERATURE: -25° C~+85° C.
 工作温度: -25° C~+85° C.

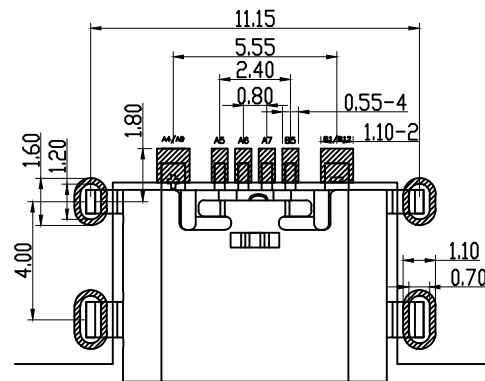
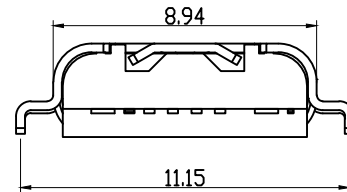
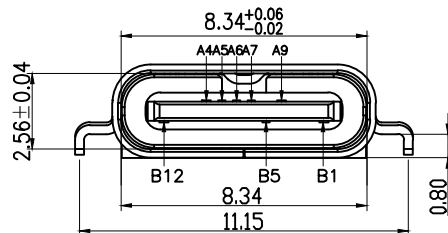
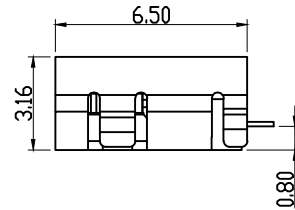
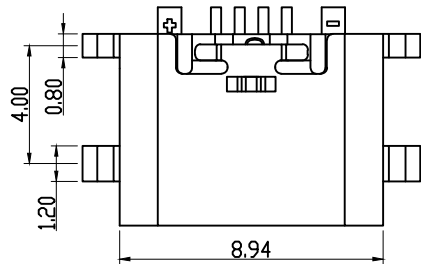
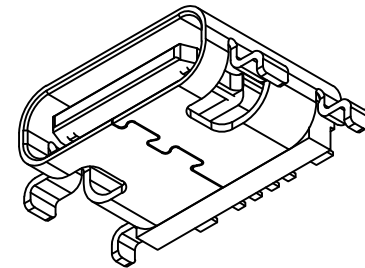
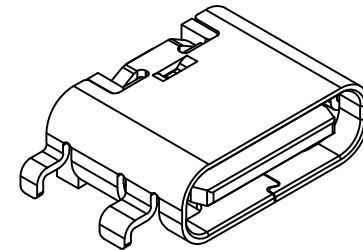

RECOMMENDED P. C. B. LAYOUT
 TOLERANCE UNSPECIFIED ±0.05mm

PIN NUMBER	SIGNAL NAME
A1	GND
A4	V BUS
A5	CC1
A6	Dp1
A7	Dn1
A8	SW1
A9	V BUS
A12	GND

PIN NUMBER	SIGNAL NAME
B12	GND
B5	CC2
B1	GND

CUSTOMER DRAWING			铭创科技(东莞)有限公司 Mingchuang Technology (Dongguan) Co., Ltd		
UNITS mm	SCALE 1:1	SHEET 1 OF 2	TITLE TYPE C母座6PIN 沉板0.8 四脚插板SMT L=6.5 带数据		
PROJECTION: 	DRAW: DAP	CHECK: HWT	MAT'L SEE TABLE	FINISH SEE TABLE	
GENERAL TOLERANCE .000 ±0.02 .00 ±0.10 .0 ±0.20 .0 ±2° .00 ±1°	APPD: HHM	DWG. NO. A01E607A	PART NO.	SIZE A4	



REV	DESCRIPTION	DATE	APPROVED
A	新板发行	2023.05.05	HHM

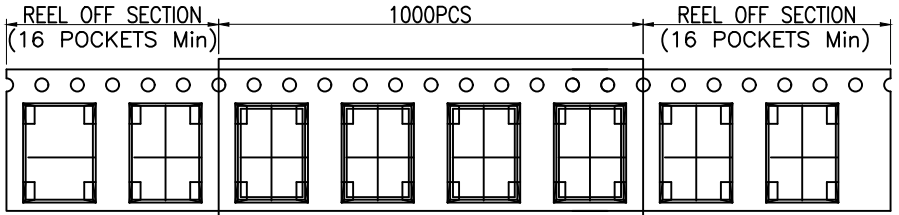

SEE DETAIL X

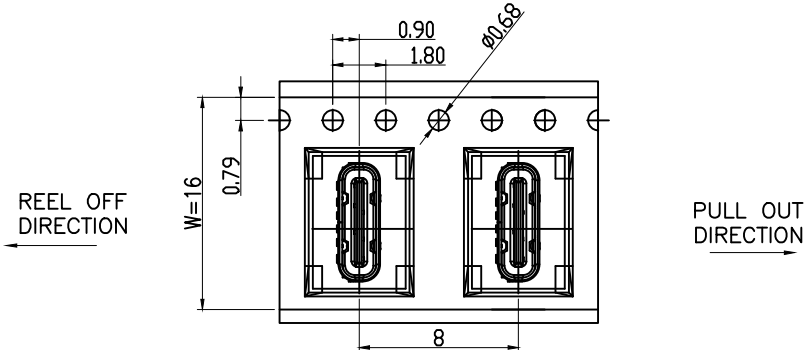
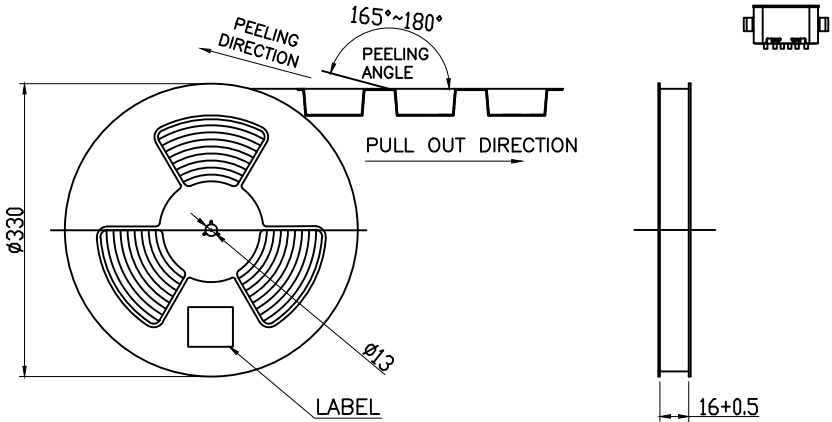
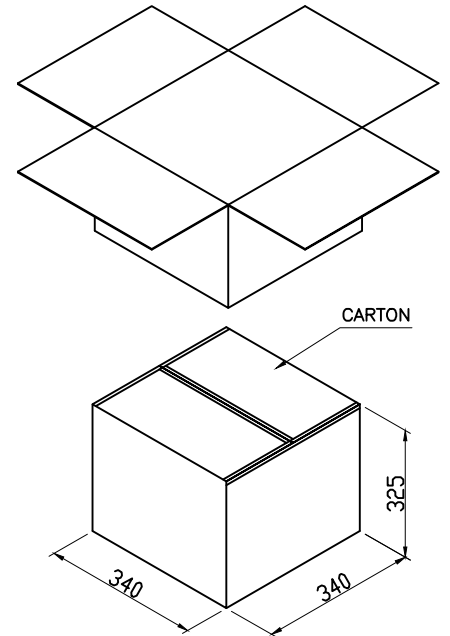
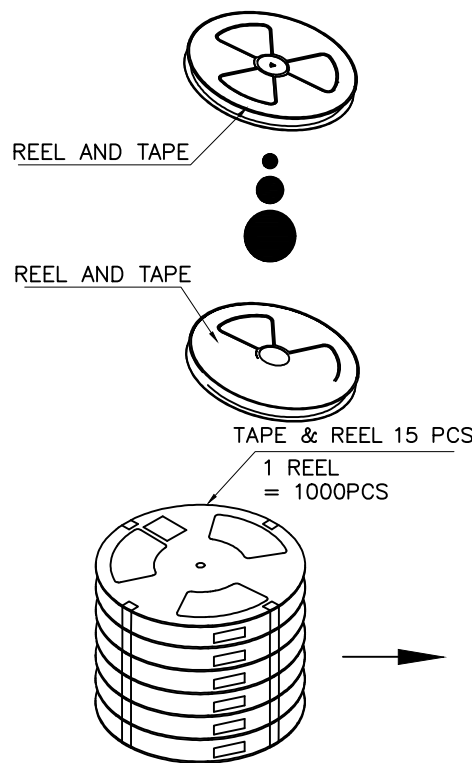

	REEL	CARTON
CONNECTOR (PCS)	1000	10000

CUSTOMER DRAWING			铭创科技(东莞)有限公司 Mingchuang Technology (Dongguan) Co., Ltd		
UNITS mm	SCALE 1:1	SHEET 2 OF 2	TITLE TYPE C母座6PIN 沉板0.8 四脚插板SMT L=6.5 带数据		
PROJECTION: 	DRAW: DAP		MAT'L SEE TABLE		
GENERAL TOLERANCE .000 ±0.02 .00 ±0.10 .0 ±0.20 .0 ±2° .00 ±1°		CHECK: HWT	FINISH SEE TABLE		
		APPD: HHM	DWG. NO. A01E607A	PART NO. _____	SIZE A4