

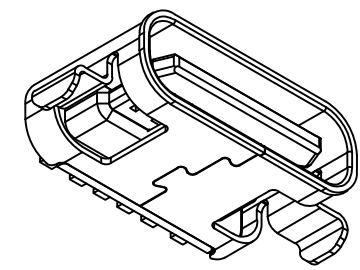

REV	DESCRIPTION	DATE	APPROVED
A	新板发行	2023.05.05	HHM

NOTE:

- 备注:
 1.MATERIAL SPECIFICATION:
 1.材料规格:
 1-1.HOUSING:HIGH TEMPERATURE RESISTANT PLASTIC,UL94 V-0.
 1-1.胶芯材料:高温塑胶,防火等级UL94 V-0
 1-2.TERMINAL: COPPER ALLOY
 1-2.端子材料:铜合金
 1-3.FRONT SHELL: STAINLESS STEEL
 1-3.外壳材料:不锈钢
 1-4.MID PLATE: STAINLESS STEEL
 1-4.中夹片:不锈钢
 2.PLATING SPECIFICATION:
 2.电镀规格:
 2-1.TERMINAL:
 2-1.端子:
 Ni 50u" MIN. UNDER PLATED OVER ALL.
 镀镍底 50u" MIN.
 Au PLATED 0.5~1u" OVER Ni
 表面刷金0.5~1u"
 2-2.FRONT SHELL:
 2-2.外壳:
 Ni 50u" MIN. PLATED OVER ALL.
 镀镍底 50u" MIN.
 3.MECHANICAL PERFORMANCE,
 3.机械性能,
 3-1.INSERTION FORCE: 0.5~2.0kgf.
 3-1.插入力: 0.5~2.0kgf.
 3-2.REMOVAL FORCE: 0.6kgf~2.0kgf.
 3-2.拔出力: 0.6kgf~2.0kgf.
 3-3.DURABILITY: 10000 CYCLES.
 3-3.插拔寿命: 10000次.
 4.ELECTRICAL PERFORMANCE,
 4.电气性能,
 4-1. VOLTAGE RATING: 5.0V DC/AC
 4-1. 额定电压: 5.0V DC/AC
 CURRENT RATING: 2.0A
 额定电流: 2.0A
 4-2. LLCR: 50mΩ/PIN MAX.
 4-2. 接触阻抗: 50mΩ/PIN MAX.
 4-3.INSULATION RESISTANCE: 100MΩ MIN
 4-3. 绝缘阻抗: 100MΩ MIN
 4-4.DIELECTRIC WITHSTAND VOLTAGE,AC 100V FOR 1 MINUTE.
 4-4. 耐电压: AC 100V FOR 1 MINUTE.
 5. ENVIRONMENTAL PERFORMANCE:
 5. 环境特性:
 OPERATING TEMPERATURE: -25°C~+85°C.
 工作温度: -25°C~+85°C.

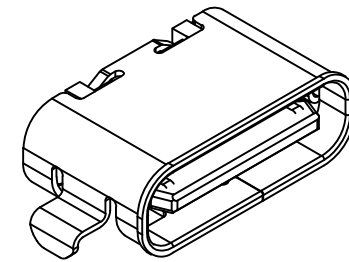

PIN ASSIGNMENTS

A1	GND	B9	VBUS
A5	CC1	B5	CC2
A12	GND	B4	VBUS
PIN	SIGNAL NAME	PIN	SIGNAL NAME

CUSTOMER DRAWING		
UNITS mm	SCALE 1:1	SHEET 1 OF 1
PROJECTION: 	DRAW: DAP	
GENERAL TOLERANCE .000 ±0.02 .00 ±0.10 .0 ±0.20 .0 ±2° .00 ±1°	CHECK: HWT	MAT'L SEE TABLE FINISH SEE TABLE
	APPD: HHM	
	DWG. NO. A01C615A	

铭创科技(东莞)有限公司 Mingchuang Technology (Dongguan) Co., Ltd	
TITLE TYPE C母座6PIN 沉板0.8 两脚插板SMT L=5.15 带中夹片 无弹 卷边	
DWG. NO. A01C615A	

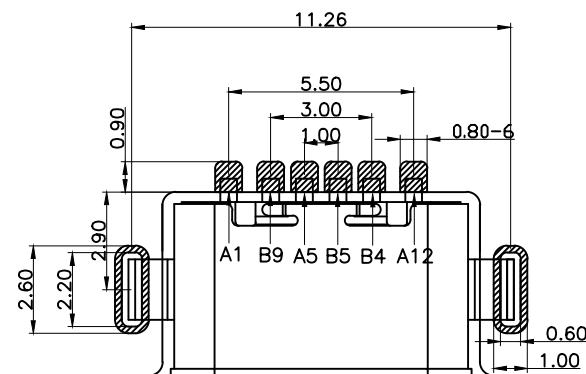
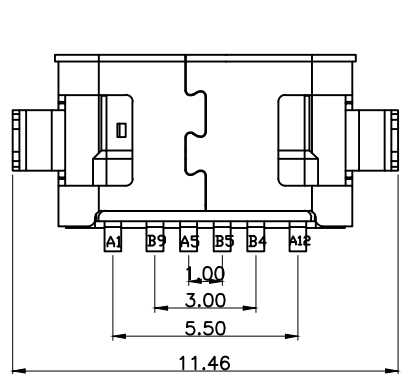
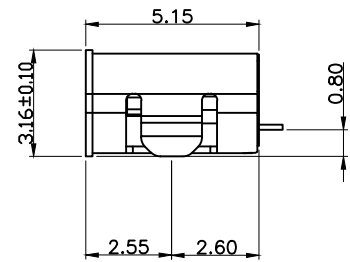
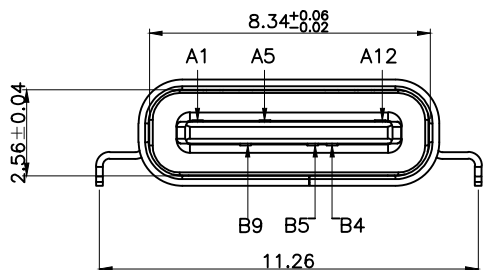
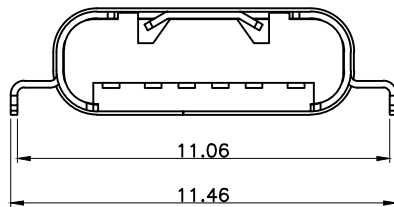
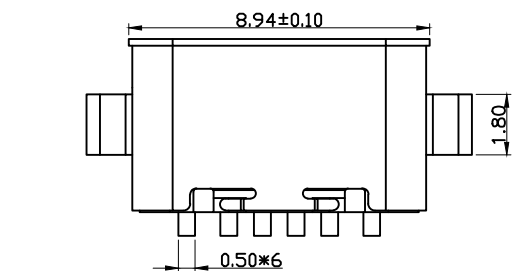



REV	DESCRIPTION	DATE	APPROVED
A	新板发行	2023.05.05	HHM

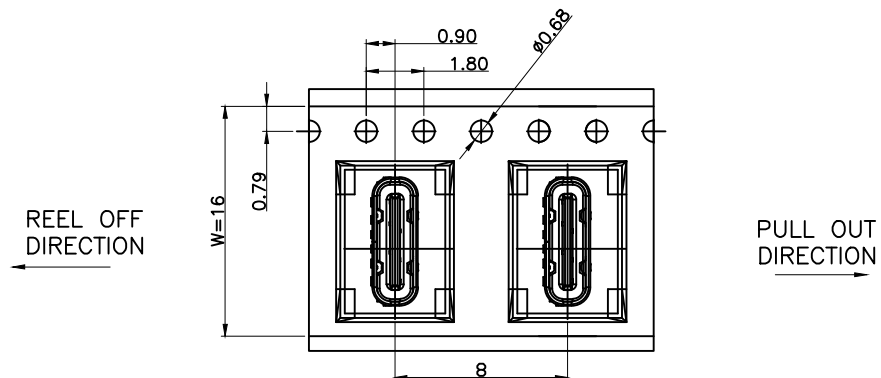
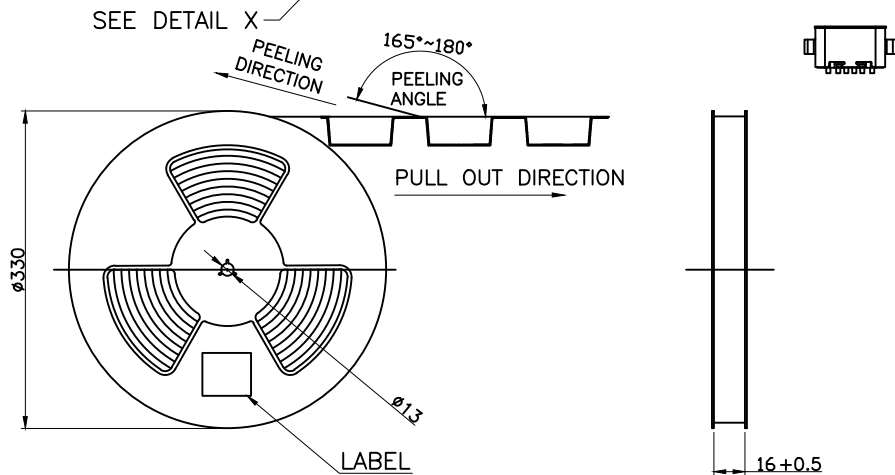
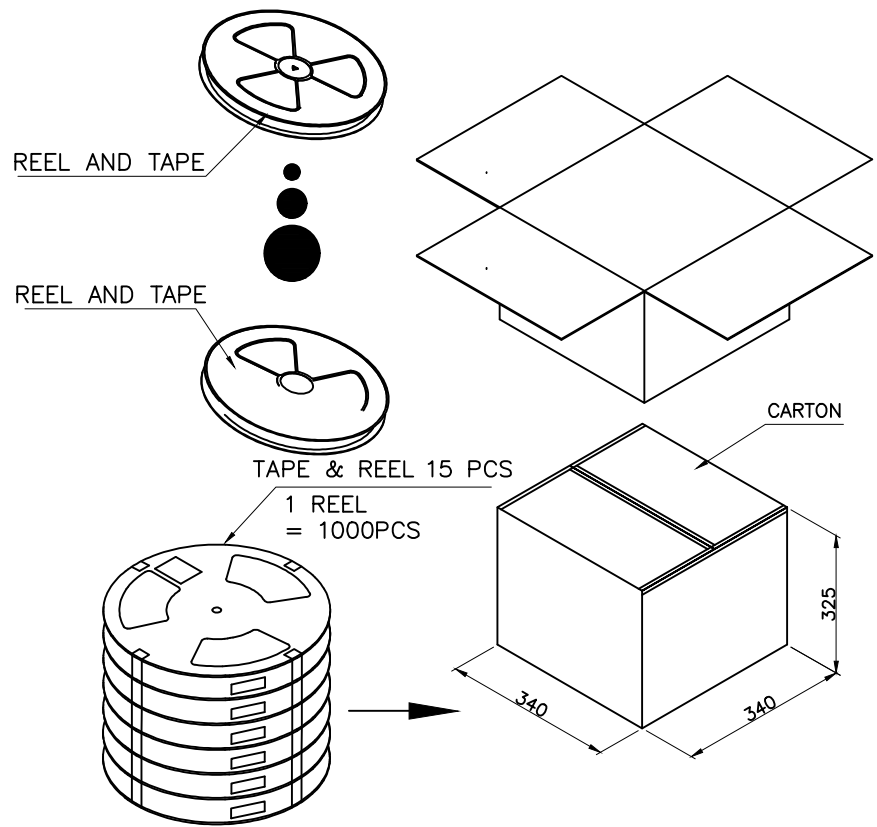
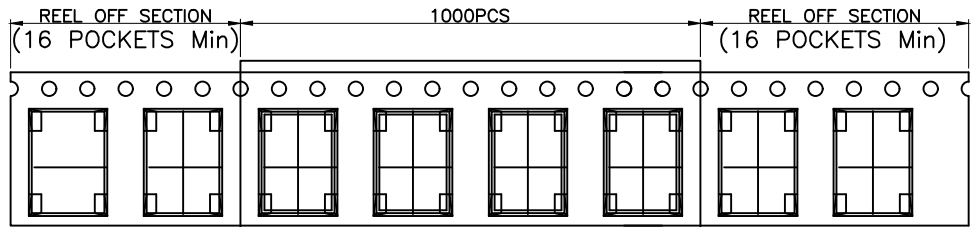

	REEL	CARTON
CONNECTOR (PCS)	1000	10000

CUSTOMER DRAWING			铭创科技(东莞)有限公司 Mingchuang Technology (Dongguan) Co., Ltd		
UNITS mm	SCALE 1:1	SHEET 2 OF 2	TITLE TYPE C母座6PIN 沉板1.6 两脚插板SMT L=5.15 带中夹片 无弹 卷边		
PROJECTION: 	DRAW: DAP		MAT'L	FINISH	
GENERAL TOLERANCE .000 ±0.02 .00 ±0.10 .0 ±0.20 .0 ±2° .00 ±1°	CHECK: HWT	APPD: HHM	SEE TABLE	SEE TABLE	
	DWG. NO. A01C617A	PART NO.	SIZE A4		