

RECOMMENDED P.C.B. LAYOUT (俯视图)
TOLERANCE UNSPECIFIED ±0.05mm

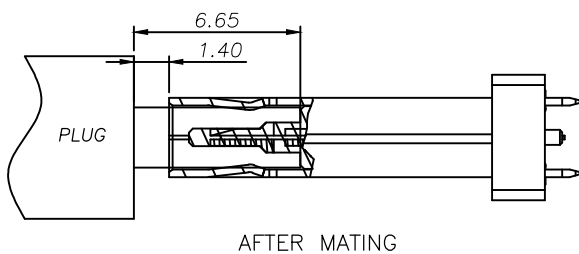
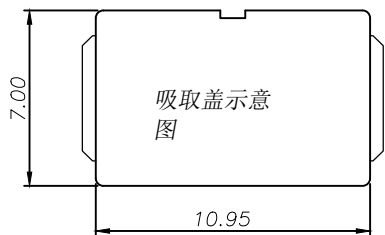
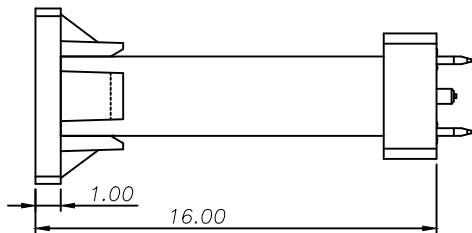
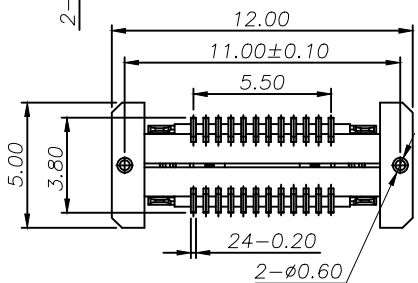

REV	DESCRIPTION	DATE	APPROVED

SPECIFICATION:

- 1' ELECTRICAL:
 - 1.1 CURRENT RATING:5A;
 - 1.2 CONTACT RESISTANCE:40mΩ Max;
 - 1.3 DIELECTRIC WITHSTANDING VOLTAGE:100V AC;
 - 1.4 INSULATION RESISTANCE:100 MΩ MIN;
- 2' MECHANICAL;
 - 2.1 MATING FORCE:5~20N;
 - 2.2 UNMATING FORCE:8~20N;
 - 2.3 DURABILITY:10000 CYCLES;6~20N AFTER DURABILITY TEST;
- 3' MATERIAL:
 - 3.1 HOUSING&MOLDING:BLACK LCP UL94V-0;
 - 3.2 TERMINAL:C18400 T=0.12mm;
 - 3.3 SHELL:SUS304 T=0.30mm;
 - 3.4 MID PLATE:SUS301 T=0.15mm;
- 4' PLATING SPECIFICATION:
 - 4.1 TERMINAL:CONTACT POINT GOLD PLATED 3u"Min
PIN WELDING AREA GOLD PLATED 1u"Min.
 - 4.2 NI 40U"Min. UNDER PLATED OVER ALL.
 - 4.3 SHELL:PLATED Ni 50u"Min(Salt spray 48H)
- 5' ELECTROPLATED PRODUCTS NEED TO UNDERGO TIN ADHESION TESTING: THE TIN ADHESION AREA SHOULD REACH OVER 95%.
- 6' SMT REFLOW SOLDERING (PEAK VALUE 260 °C ± 5 ° C) SHALL BE FREE OF BLISTERING, GLUE MELTING AND POOR COLOR CHANGE (DEFORMATION WITHIN TOLERANCE)
- 7' OPERATING TEMPERATURE : -40°C~+85°C

A1	GND	B12	GND
A2	TX1+	B11	RX1+
A3	TX1-	B10	RX1-
A4	VBUS	B9	VBUS
A5	CC1	B8	SBU2
A6	D+	B7	D-
A7	D-	B6	D+
A8	SBU1	B5	CC2
A9	VBUS	B4	VBUS
A10	RX2-	B3	TX2-
A11	RX2+	B2	TX2+
A12	GND	B1	GND
PIN	SIGNAL NAME	PIN	SIGNAL NAME

CUSTOMER DRAWING		
UNITS mm	SCALE 1:1	SHEET 1 OF 2
PROJECTION: 	DRAW: DAP	
GENERAL TOLERANCE X. ±0.25 X.x ±0.20 X.xx ±0.15 X.xxx ±0.10 ANGLES ±2°	CHECK: HWT	MAT'L SEE TABLE
	APPD: HHM	
	DWG. NO. A032401A	

铭创科技 (东莞) 有限公司 Mingchuang Technology (Dongguan) Co., Ltd	
TITLE TYPE C母座24PIN 立式四脚插板SMT L=15.0	
DWG. NO. A032401A	

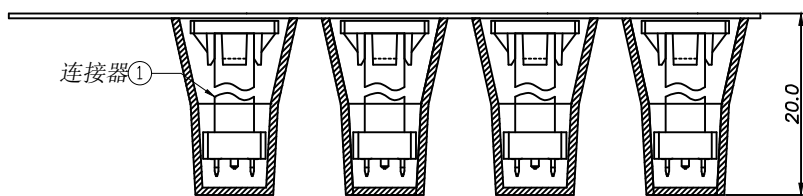
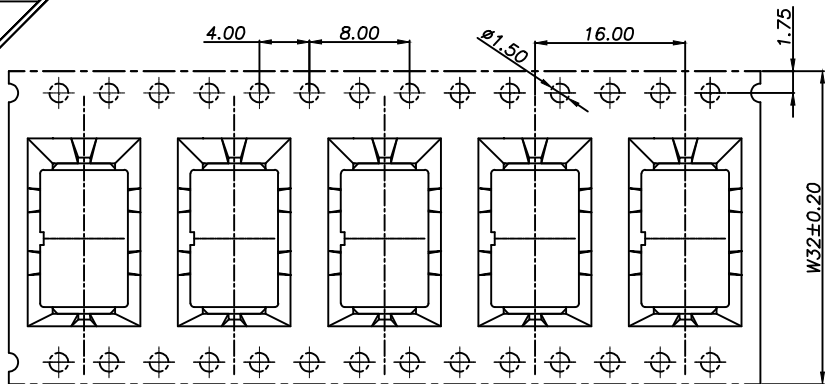
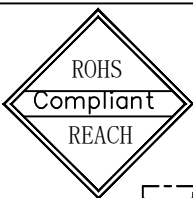

产品入载带示意图

剥离角度: 165°~180°
剥离力: 40gf~120gf
用户取件方向

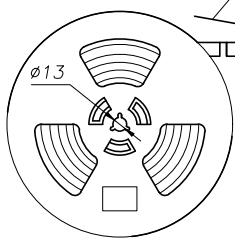
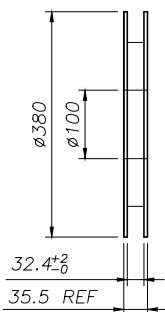

卷盘示意图

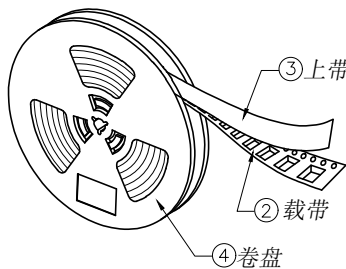

REV	DESCRIPTION	DATE	APPROVED

包装示意图

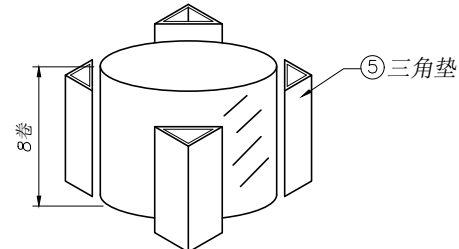
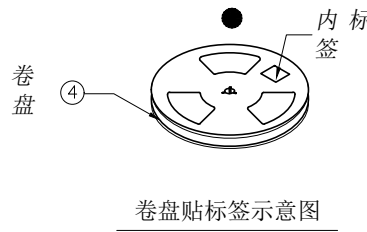
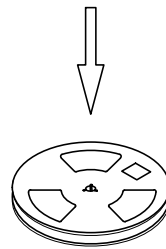

8盘产品叠层示意图

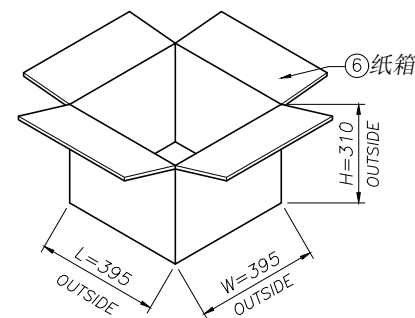

技术要求:

- 载带首尾各留出 12PCS 空格 不装产品;
- 每穴放置 1PCS 产品, 每卷装 300PCS 产品, 放置方式如图所示;
- 将包装好的产品;每盘必需贴上内标签;将贴好内标签的产品每8盘堆叠.
- 在纸箱四角垫上 4 个三角垫, 然后把装好产品的卷盘放入纸箱中, 最后用胶带封箱; (如客户有要求, 请按客户要求包装出货)
- 上带与载带的剥离力: 40gf~120gf, 跳动量在 30gf 内; (剥离角度: 165°~180°, 剥离速度: 250~300mm/min)
- 产品符合 RoHS 环保标准要求.

CUSTOMER DRAWING

UNITS mm	SCALE 1:1	SHEET 2 OF 2
PROJECTION: 		DRAW: DAP
GENERAL TOLERANCE X. ±0.25 X.x ±0.20 X.xx ±0.15 X.xxx ±0.10 ANGLES ±2°		CHECK: HWT APPD: HHM

铭创科技 (东莞) 有限公司
Mingchuang Technology (Dongguan) Co., Ltd

TITLE
TYPE C 母座 24PIN 立式四脚插板 SMT
L=15.0

MAT'L
SEE TABLE
FINISH
SEE TABLE

DWG. NO. A032401A
PART NO. _____
SIZE A4

06	纸箱	B-05-0012	395mm*395mm*310mm	1 PCS
05	三角垫	/	300mm*260mm*7mm	4 PCS
04	卷盘	/	D=380mm, d=100mm, H=35.50mm	8 PCS
03	上带	/	W=25.5mm, T=0.05mm	5184 mm
02	载带	B-03-0018	W=32mm, T=0.50mm, P=16.0mm	5184 mm
01	连接器	A032401A	24PIN, SMT	2400 PCS
序号	物料名称	物料编号	规格	描述