

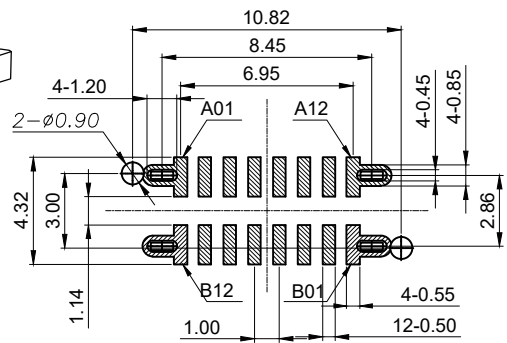

REV	DESCRIPTION	DATE	APPROVED

- SPECIFICATION:**
- ELECTRICAL:**
 - CURRENT RATING:5A;
 - CONTACT RESISTANCE:40mΩ Max;
 - DIELECTRIC WITHSTANDING VOLTAGE:100V AC;
 - INSULATION RESISTANCE:100 MΩ MIN;
 - MECHANICAL:**
 - MATING FORCE:5~20N;
 - UNMATING FORCE:8~20N;
 - DURABILITY:10000 CYCLES;6~20N AFTER DURABILITY TEST;
 - MATERIAL:**
 - HOUSING&MOLDING:BLACK LCP UL94V-0;
 - TERMINAL:C7025 T=0.15mm;
 - SHELL:SUS304 T=0.30mm;
 - MID PLATE:SUS304 T=0.15mm;
 - PLATING SPECIFICATION:**
 - TERMINAL:CONTACT POINT GOLD PLATED 3u "MIN PIN WELDING AREA GOLD PLATED 1u" MIN.
 - SHELL:PLATED Ni 60u" MIN(Salt spray 48H)
 - ELECTROPLATED PRODUCTS NEED TO UNDERGO TIN ADHESION TESTING: THE TIN ADHESION AREA SHOULD REACH OVER 95%.**
 - SMT REFLOW SOLDERING (PEAK VALUE 260 °C ± 5 ° C) SHALL BE FREE OF BLISTERING, GLUE MELTING AND POOR COLOR CHANGE (DEFORMATION WITHIN TOLERANCE)**
 - OPERATING TEMPERATURE: -40°C~+85°C**

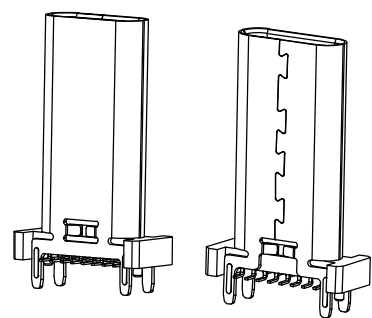
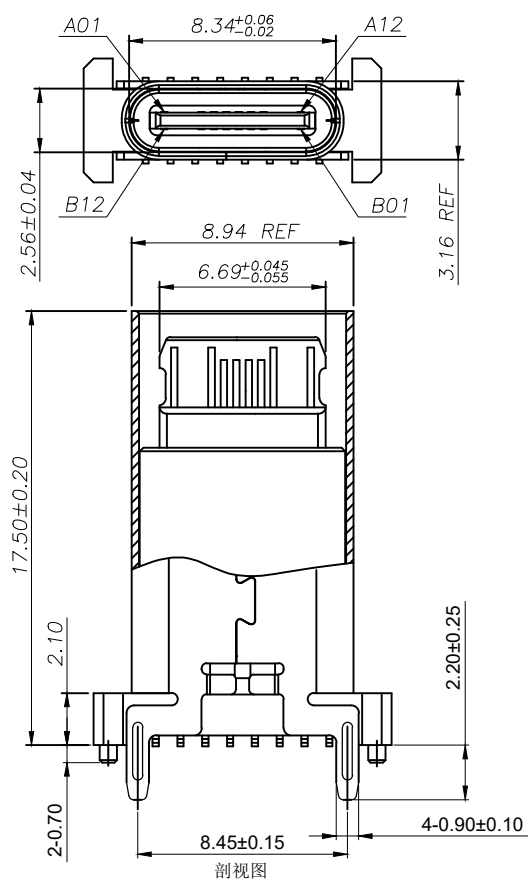

RECOMMENDED P.C.B. LAYOUT (俯视图)
TOLERANCE UNSPECIFIED ±0.05mm

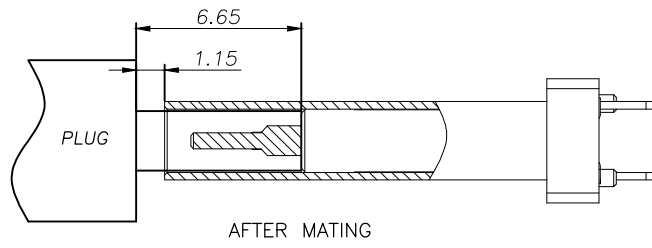
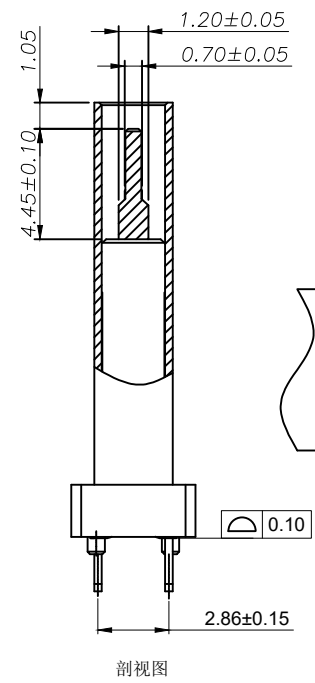

A1	GND	B12	GND
A4	VBUS	B9	VBUS
A5	CC1	B8	SBU2
A6	D+	B7	D-
A7	D-	B6	D+
A8	SBU1	B5	CC2
A9	VBUS	B4	VBUS
A12	GND	B1	GND
PIN	SIGNAL NAME	PIN	SIGNAL NAME

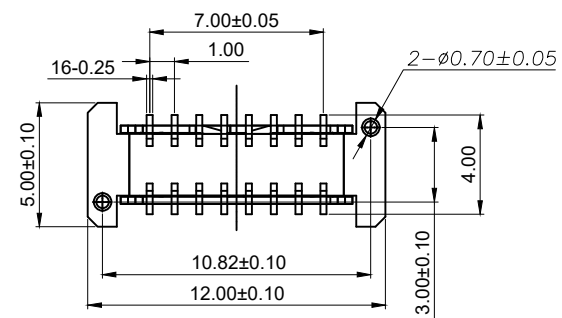

CUSTOMER DRAWING		
UNITS mm	SCALE 1:1	SHEET 1 OF 2
PROJECTION: 	DRAW: DAP	
GENERAL TOLERANCE X. ±0.25 X.x ±0.20 X.xx ±0.15 X.xxx ±0.10 ANGLES ±2°	CHECK: HWT	MAT'L SEE TABLE
	APPD: HHM	FINISH SEE TABLE
	DWG. NO. A031603A	

铭创科技 (东莞) 有限公司 Mingchuang Technology (Dongguan) Co., Ltd	
TITLE TYPE C母座16PIN 立式四脚插板SMT L=17.5 A款	
DWG. NO. A031603A	
PART NO.	SIZE A4



REV	DESCRIPTION	DATE	APPROVED

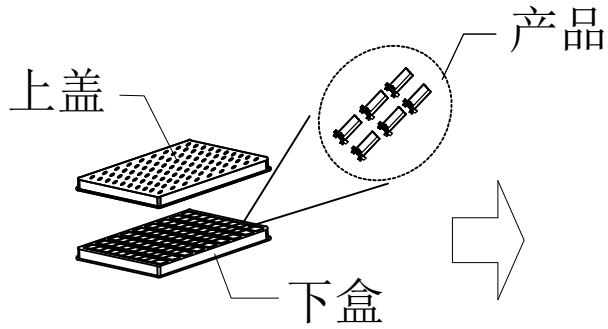

① PE真空盒(1Set).



② 100Pcs/盒

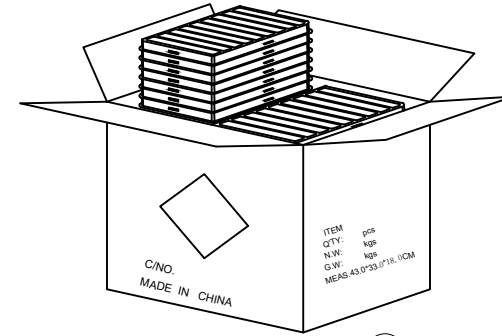

③ 50盒/箱(5k).

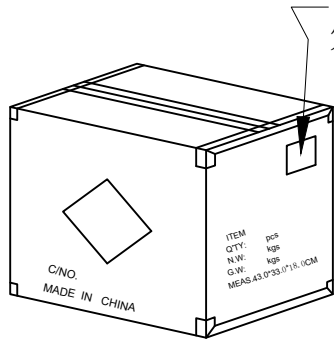

⑥ 依图示粘贴产品或RoHS标签.

外箱物料标签

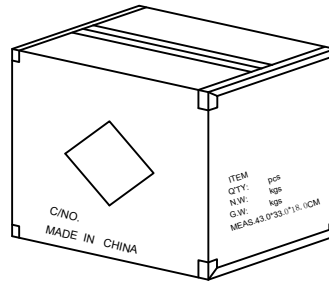

⑤ 外箱用透明胶纸带封“工”字型.

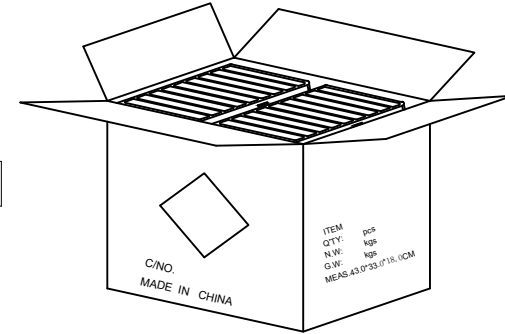

④ 每箱竖放25盒*2,若尾数箱在空间处加装填充物.

04	纸箱	B-05-0004	430mm*330mm*180mm	1 PCS
03	上盖	B-01-0001	PET透明 T0.3*L305*W205*H11mm	50 PCS
02	下盒	B-01-0002	PET透明 T0.3*L305*W205*H11mm	50 PCS
01	连接器	A031603A	16PIN, SMT	5000 PCS
序号	物料名称	物料编号	规格	描述

CUSTOMER DRAWING			铭创科技(东莞)有限公司 Mingchuang Technology (Dongguan) Co., Ltd		
UNITS mm	SCALE 1:1	SHEET 2 OF 2	TITLE TYPE C母座16PIN 立式四脚插板SMT L=17.5 A款		
PROJECTION: 	DRAW: DAP	CHECK: HWT	MAT'L SEE TABLE	FINISH SEE TABLE	
GENERAL TOLERANCE X. ±0.25 X.x ±0.20 X.xx ±0.15 X.xxx ±0.10 ANGLES ±2°	APPD: HHM	DWG. NO. A031603A	PART NO. _____	SIZE A4	