

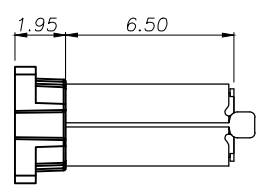

REV	DESCRIPTION	DATE	APPROVED

**SPECIFICATION:**

- ELECTRICAL:**
  - CURRENT RATING:5A;
  - CONTACT RESISTANCE:40mΩ Max;
  - DIELECTRIC WITHSTANDING VOLTAGE:100V AC;
  - INSULATION RESISTANCE:100 MΩ MIN;
- MECHANICAL:**
  - MATING FORCE:5~20N;
  - UNMATING FORCE:8~20N;
  - DURABILITY:10000 CYCLES;6~20N AFTER DURABILITY TEST;
- MATERIAL:**
  - HOUSING&MOLDING:BLACK LCP UL94V-0;
  - TERMINAL:C7025 T=0.15mm;
  - SHELL:SUS304 T=0.30mm;
  - MID PLATE:SUS304 T=0.20mm;
- PLATING SPECIFICATION:**
  - TERMINAL:CONTACT POINT GOLD PLATED 3u"Min  
PIN WELDING AREA GOLD PLATED 1u"Min.
  - 2.NI 40U" MIN. UNDER PLATED OVER ALL.
  - SHELL:PLATED Ni 50u" Min(Salt spray 48H)
- ELECTROPLATED PRODUCTS NEED TO UNDERGO TIN ADHESION TESTING: THE TIN ADHESION AREA SHOULD REACH OVER 95%.**
- SMT REFLOW SOLDERING (PEAK VALUE 260 °C ± 5 ° C) SHALL BE FREE OF BLISTERING, GLUE MELTING AND POOR COLOR CHANGE (DEFORMATION WITHIN TOLERANCE)**
- OPERATING TEMPERATURE: -40°C~+85°C**

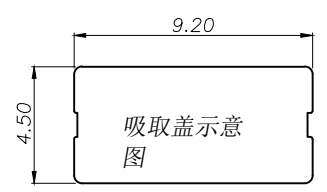
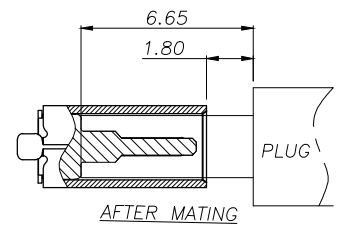
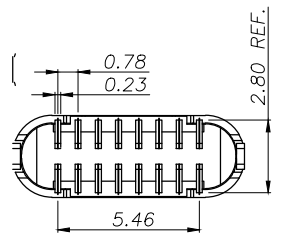
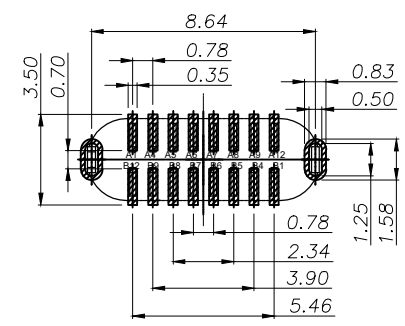
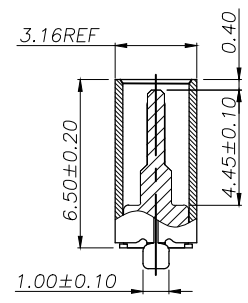
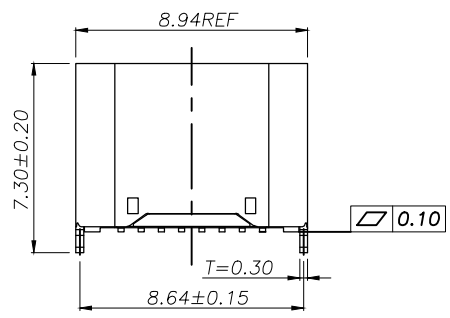
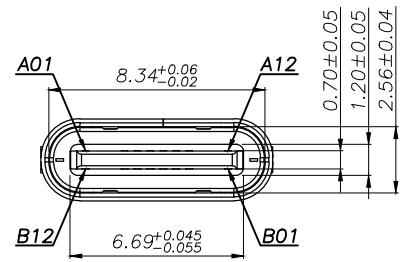
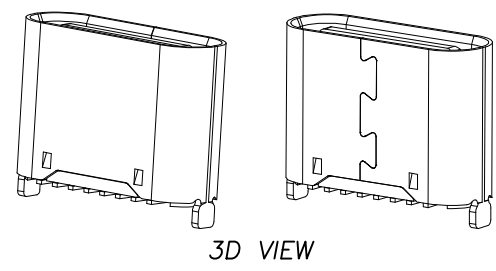

A1	GND	B12	GND
A4	VBUS	B9	VBUS
A5	CC1	B8	SBU2
A6	D+	B7	D-
A7	D-	B6	D+
A8	SBU1	B5	CC2
A9	VBUS	B4	VBUS
A12	GND	B1	GND
PIN	SIGNAL NAME	PIN	SIGNAL NAME

<b>CUSTOMER DRAWING</b>			<b>铭创科技 (东莞) 有限公司</b> Mingchuang Technology (Dongguan) Co., Ltd		
UNITS mm	SCALE 1:1	SHEET 1 OF 2	TITLE TYPE C母座16PIN 立式两脚插板SMT L=6.5 C款		
PROJECTION: 	DRAW: DAP		MAT'L SEE TABLE	FINISH SEE TABLE	
GENERAL TOLERANCE X. ±0.25 X.x ±0.20 X.xx ±0.15 X.xxx ±0.10 ANGLES ±2°	CHECK: HWT	APPD: HHM	DWG. NO. A031625A	PART NO.	SIZE A4

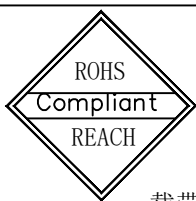

载带②

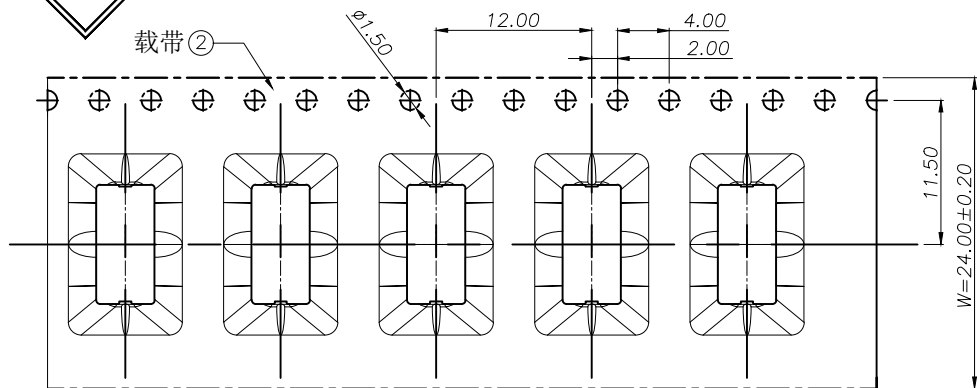

连接器①

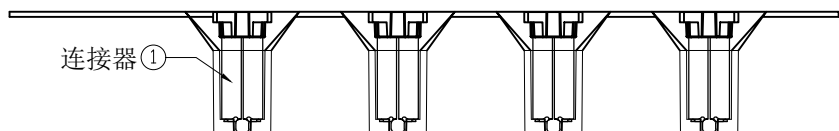

产品入载带示意图

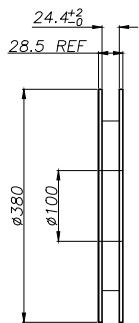

剥离角度: 165°~180°  
剥离力: 40gf~80gf

用户取件方向

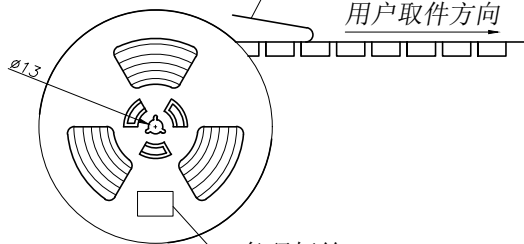

条码标签

卷盘示意图

05	纸箱	B-05-0012	390mm*390mm*310mm	1 PCS
04	卷盘	/	D=380mm, d=100mm, H=28.5mm	10 PCS
03	上带	/	W=20.7mm, T=0.05mm	9600 mm
02	载带	B-03-0023	W=24mm, T=0.50mm, P=12.0mm	9600 mm
01	连接器	A031625A	16PIN, SMT	8000 PCS
序号	物料名称	物料编号	规格	描述

REV	DESCRIPTION	DATE	APPROVED

包装方向示意图

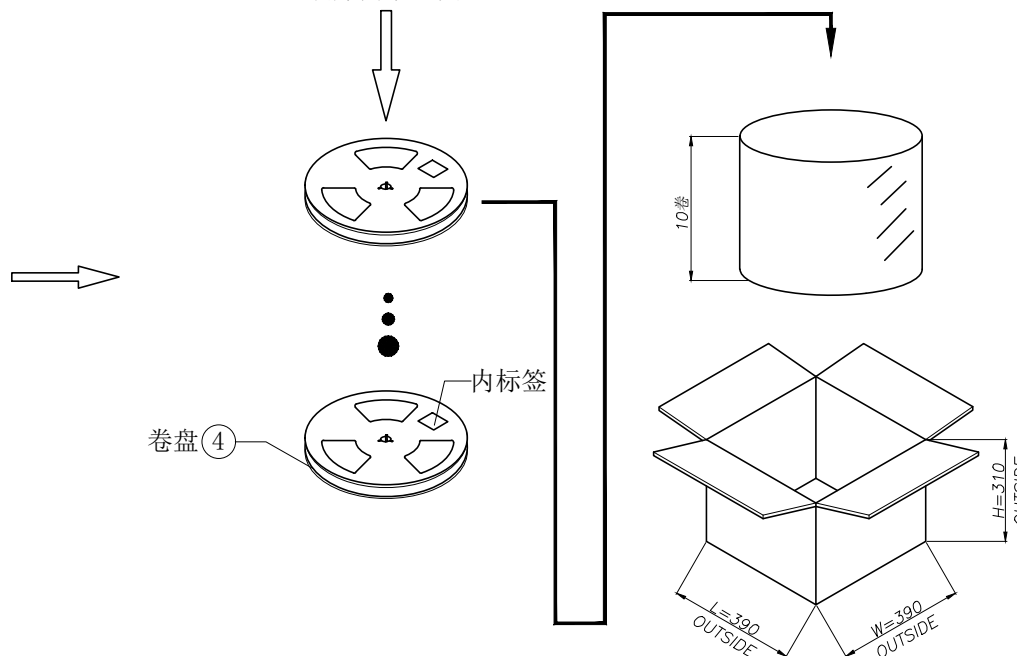

技术要求:

- 载带首尾各留出 10PCS 空格 不装产品;
- 每穴放置 1PCS 产品, 每卷装 800PCS 产品, 放置方式如图所示;
- 将包装好的产品;每盘必需贴上内标签;将贴好内标签的产品每 10 盘堆叠;
- 在纸箱四角垫上 4 个三角垫, 然后把装好产品的卷盘放入纸箱中, 最后用胶带封箱;  
(如客户有要求, 请按客户要求包装出货)
- 上带与载带的剥离力: 40gf~120gf, 跳动量在 30gf 内;  
(剥离角度: 165°~180°, 剥离速度: 250~300mm/min)
- 产品符合 RoHS 环保标准要求.

CUSTOMER DRAWING			铭创科技 (东莞) 有限公司		
UNITS mm	SCALE 1:1	SHEET 2 OF 2	Mingchuang Technology (Dongguan) Co., Ltd		
PROJECTION: 	DRAW: DAP	TITLE TYPE C 母座 16PIN 立式两脚插板 SMT L=6.5 C 款			
GENERAL TOLERANCE X. ±0.25 X.x ±0.20 X.xx ±0.15 X.xxx ±0.10 ANGLES ±2°		CHECK: HWT	MAT'L SEE TABLE	FINISH SEE TABLE	
APPD: HHM		DWG. NO. A031625A	PART NO.	SIZE A4	